

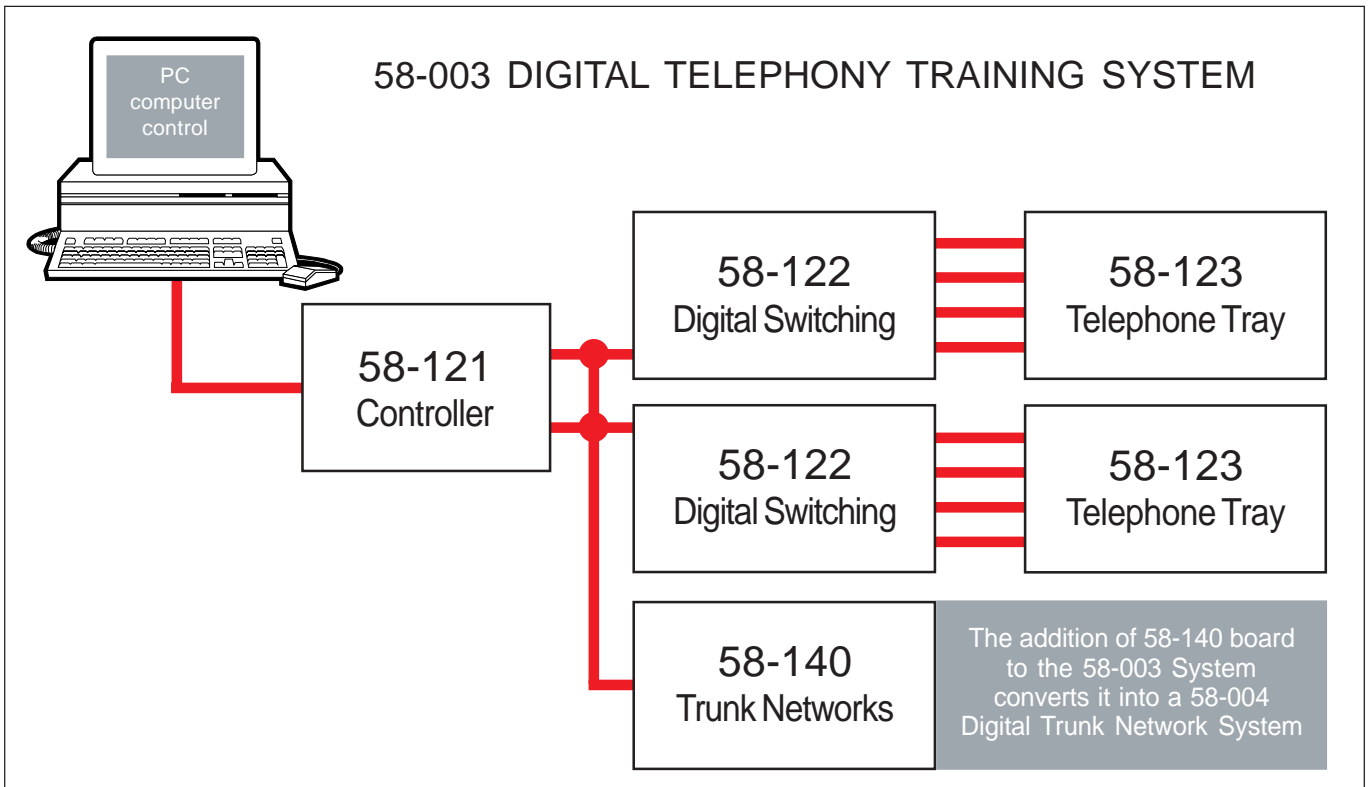

Telephony Trainers with Discovery Software

- 58-001 Telephony Training System
- 58-002 Digital Switching System
- 58-003 Digital Telephony Training System
- 58-004 Digital Trunk Network System

Telephony Training Systems

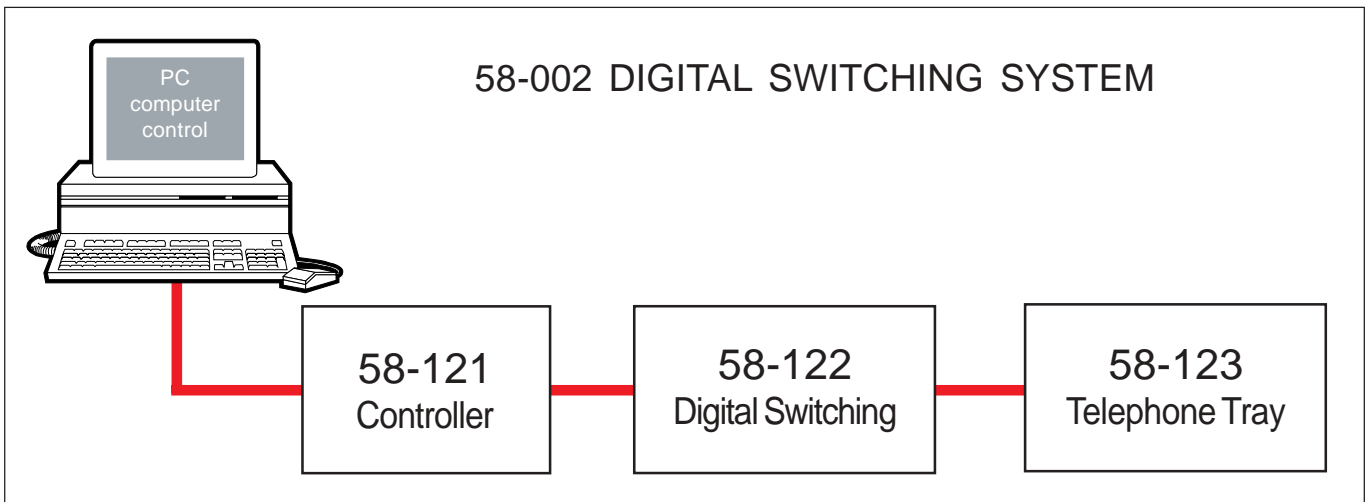
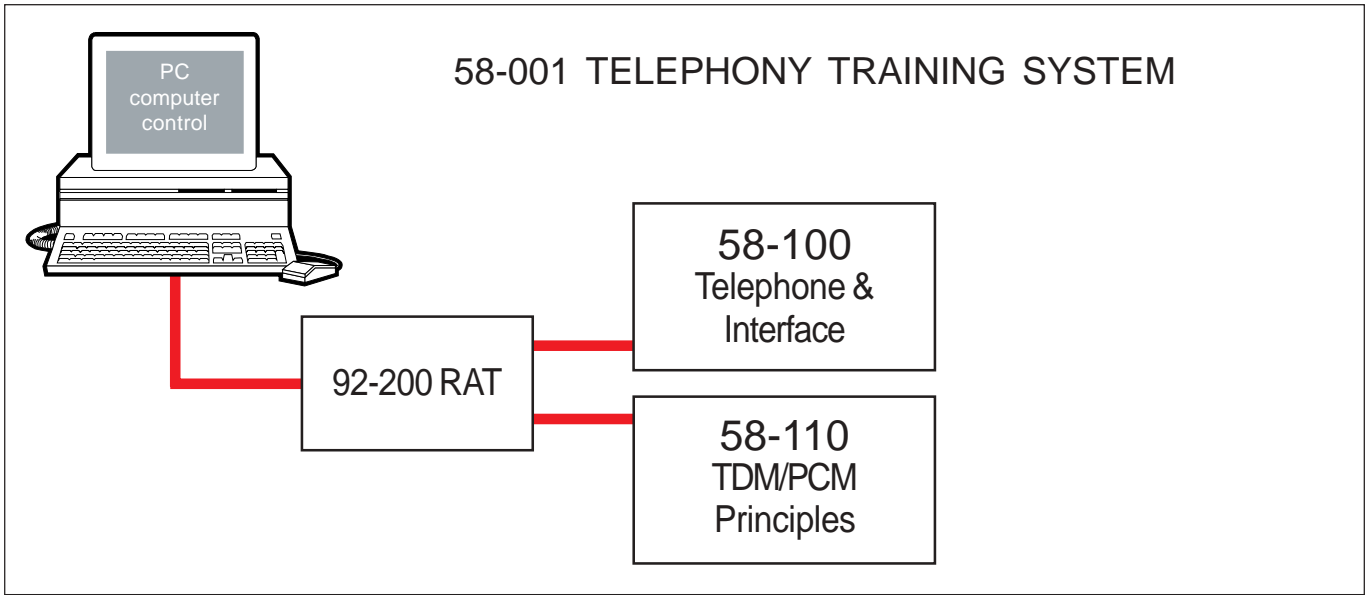

Features

- Covers telephony principles and modern practice
- Uses commercial telephony components
- Provides access to all signals
- Uses Discovery software
- Automatic practical configuration - no patching

Description

Telephones and telephony are an essential part of modern living and telecommunications is one of the world's fastest growing industries. The demand for technicians and engineers with knowledge of the principles of this area of technology will increase with this growth.

This range of Telephony Trainers with Discovery software is a modern, PC-based, computer controlled training system that has been designed to introduce and demonstrate the principles of modern telephone systems.

The Trainers are a combination of hardware workboards and Discovery software, which together provide a totally integrated delivery system for teaching a wide spectrum of telephony concepts and applications, from the characteristics of individual components to the use of complex systems.

Complete Systems

Each Telephony Workstation consists of:

- Workstation computer
- Interface system
Real-time Access Terminal (RAT) or
Controller
One or more Telephony workboards
- Discovery Software

Interface System

The Telephony Training System includes a USB Real-time Access Terminal (RAT) for interface to the PC.

The Digital Switching System includes a Controller unit to provide all the special power supplies and PC interface circuitry.

Discovery Software

In combination with the hardware, Discovery Software is supplied with the system. This forms an innovative and motivating delivery system which enables a wide range of tuition to be carried out.

Background theory, board configuration, practical control, instructions and questions, together with PC-based instrumentation is all integrated into the Discovery environment, supplying all the instruction and measurement requirements for the experiments. The test points used by the PC-based instrumentation in the experiments are duplicated on the workboard, allowing standard Test instruments to be connected if required.

Discovery software is a browser-based delivery system enabling instructional, integrated hardware control. It allows totally free movement between software screens and has a user-friendly graphical interface.

The computer configuration of the workboards available with Discovery software eliminates practical set-up time, ensuring that the correct connections are automatically made.

This significantly increases the time available for actual practical work and the efficiency of laboratory sessions.

Curriculum

In addition to the integral Discovery software, each Workstation is supported by manuals provided on a CD ROM (together with the Discovery software) a Student Workbook and an Installation Manual.

The Student Workbook has been designed to be used alongside the on-screen Discovery software. For each assignment, the Learning Outcomes and Competencies are listed and students demonstrate their achievement of competence by satisfactorily completing the Workbook. This involves such activities as supplying missing keywords, completing block diagrams, making measurements, sketching waveforms, etc. The Workbook has sections for answering the on-screen Discovery questions. In addition, the Workbook is a valuable revision aid for students, as the key points of the theoretical and background work to assignments are also included.

The Installation Manual details the hardware and software installation and operation, the editing facility, circuit diagrams, etc. It also contains typical answers to the student activities and questions.



Description

The system comprises two boards:

- Telephone and Interface
- TDM/PCM Principles

a RAT (Real-time Access Terminal) and
Discovery Software

The Telephony Training System is a stand-alone trainer designed to enable students to study the principles of telephony and gain experience into modern telephony practice. It is a complete package dealing with telephone system theory and practice and combines industry hardware with special circuits designed to demonstrate the underlying principles.

The instruction is essentially non-mathematical and is particularly suited to vocational and technician level courses, or for the introductory principles required for further study in telephony systems in undergraduate courses.

The Telephony Training System 58-001 contains two workboards and covers a wide range of assignment work.

Curriculum

Telephone and Interface Workboard

- Telephone Signalling
 - Switch Hook
 - Keypad
 - Ringing (Alerting)
- Telephone Speech
 - Receiver
 - Transmitter (Microphone)
 - Telephone hybrid circuit
- Subscriber's Line Interface Circuit (SLIC)
 - Battery Feed
 - Overvoltage protection
 - Ringing (Alerting)
 - Signalling
- Dual Tone Multi Frequency (DTMF) signalling
 - DTMF Codes
 - Frequency Measurement
 - Tone Duration
 - Speech Immunity
- SLIC Hybrid
 - Forward loss
 - Return balance loss
- Testing
 - Test-Out
 - Test-In

TDM/PCM Principles Workboard

- Sampling
 - Sampling Introduction
 - Aliasing error
- Interference
 - Multiplexing (TDM)
 - Multiplexing Introduction
 - Time slots and Frames
- Pulse Code Modulation (PCM)
 - Quantisation
 - Quantisation noise
 - Interference
- Companding
 - Linear Conversion
 - Companding characteristic
 - Companding application
- Filtering
 - Aliasing error
 - Filtered conversion
- Multichannel PCM
 - 24 and 30 Channel Systems
 - Frame Synchronisation
 - Control

Telephone and Interface

The Telephone and Interface is an open format board which uses a commercial single-piece telephone to examine the signalling and speech circuits and the immediate interface at the exchange. The board contains an acoustic coupler to enable a tone signal to be applied to the telephone transmitter.

The operation of the telephone handset, the acoustic coupler and the circuitry associated with the Subscriber's Line Interface Circuit (SLIC) is investigated, showing the structure of the telephone with speech and signalling circuits and their operation in conjunction with the SLIC.

The three signalling circuits of the telephone are examined, as are the three speech circuits.

The functions of the first interface circuit are examined. In a commercial system they would be contained in a Subscriber's Line Interface Circuit (SLIC). Five of the functions of the BORSCHT acronym are covered.

The characteristics of dual tone multifrequency (DTMF) signalling as used for the control of telephone calls are determined.

The use of a high quality, commercial hybrid in the SLIC enables useful measurements to be made.

TDM/PCM Principles

This board allows the study of the underlying principles of time division multiplexing (TDM) and pulse code modulation (PCM). It is based on the use of standard telephony devices but also uses special circuits to enable the effects of variable sampling rate, bit rate and filtering to be demonstrated.

Pulse Amplitude Modulation (PAM) is used to demonstrate the concept of taking short samples to represent a continuous waveform.

Time Division Multiplexing is demonstrated by multi-channel Pulse Amplitude Modulation (PAM) which visually shows the principle of sharing a single physical link between different communication channels.

Constant values and audio samples are converted into digital form. The effects of quantisation are studied.

Linear A/D conversion is compared with compression and expansion using a standard codec.

The use of band-pass filters to avoid aliasing error is demonstrated.

The standard 30 channel PCM system is introduced and requirements for synchronisation and control are discussed. Comparison between 24 and 30 channel systems can be made.



Description

The Digital Switching System is an easy to use trainer for the investigation of digital telephone switching circuits and their applications.

With this system a student may study the principles of digital switching in telephony and also gain experience into modern telephony practice. The modules use both current standard telephony devices as well as special circuits designed to develop an understanding of the methods employed. The system allows the performance of a wide range of experiments within the subject area to be investigated.

Assignments include general introductory material and each practical is supported by background information and tutorial questions, in the standard Feedback Discovery format.

The System comprises a digital switching centre, a controller, four telephones and Discovery software. It is complementary to the Feedback Telephony Training System, 58-001.

Protection is provided on all units to ensure there are no dangerous voltages accessible by the students.

The assignments cover:

Local signalling

- Operation
- Tones and cadences

Digital Switch Principles

- Time switching
- Time & space switching

Digital switch control

- Control of time switch
- Connection of tones

Line scan

- Switch hook
- DTMF receivers

Call records

- Call state
- Line identities
- Call time

Line records

- Directory numbers
- Call accounting

Line maps

- Location maps
- Condition maps

State transitions

- Inputs
- Outputs
- Tasks

Call progress

- Call set up
- Call suspension
- Call release

Manual control

- Control

Testing

- Test out and loop back

Traffic

- System traffic

Curriculum Coverage

This system progresses from the hardware aspects of digital switching, including time and space switching and the control of a digital switch by a connection memory, to the software aspects of digital telephone switching and control.

Emphasis is placed on the Call State Transition Diagram, conforming to the CCITT SDL format, for control of call progress. The concepts of call state and state transition are demonstrated in detail. The three stages of call handling, set-up, supervision and clear down are demonstrated and may be manually controlled by the student.

Traffic statistics, testing and programming of the signal tones are investigated.

Controller

The Controller contains the microprocessor-based circuitry for control and the special power supplies required by the telephones and their associated circuits. It interfaces with the PC through a card supplied with the system, with controlling code downloaded from the PC on switch-on. This makes for uncomplicated upgrading via the Discovery software. Up to three exchanges may be run from one controller.

Digital Switching Centre

The Digital Switching Centre is an open-board format unit containing four complete telephone line circuits and all the digital switching and signalling associated with a modern digital telephone system. Two connections to other digital switching centres (trunk interfaces), four telephones and a convenient tray for housing them are also provided.

A system containing two switching centres may be set-up using an additional, optional Digital Switching Centre board.

Computer Connection

The system is supplied with software and hardware to interface to a PC.

Power Supply

All power supplies required by the system are provided with the trainer.



Description

This training system covers all of the work that can be performed with the Digital Switching System 58-002 and extends it to include trunk switching and message handling. The System has an additional Digital Switching Centre and its four associated telephones and includes eight extra assignments to extend the curriculum to trunk traffic topics.

The work that can be carried out with this Trainer progresses from the investigation of local and inter-switching centre numbers and their origination, through trunk switching, highways and timeslots, to call state transition diagrams and call records for a two switching centre system. CCITT (now ITUT) codes and formats are used.

The Trainer is computer-controlled and uses Discovery software: an integrated instructional and hardware control program which includes logic analysis and display of results.

The instruction is essentially non-mathematical and is particularly suited to vocational and technician level courses, or for the introductory principles required for further study of telephony systems in undergraduate courses.

The additional curriculum includes assignments on the following topics:

Trunk Configuration

- Trunk paths
- Numbering
- Tones and cadences

Trunk Switching

- Outward path
- Return path

Signal Protocol Controller

- Flags
- Frame check sequence
- Zero insertion (bit stuffing)

Trunk Signal Units

- Message signal units
- Fill-in signal units

Signalling Information Field

- Label
- Heading codes
- Address signals

Error Control

- Sequence numbers
- Buffers

Trunk State Diagrams

- Originating switch
- Dialling
- Destination switch

Trunk Call Progress

- Originating switch
- Dialling
- Destination switch

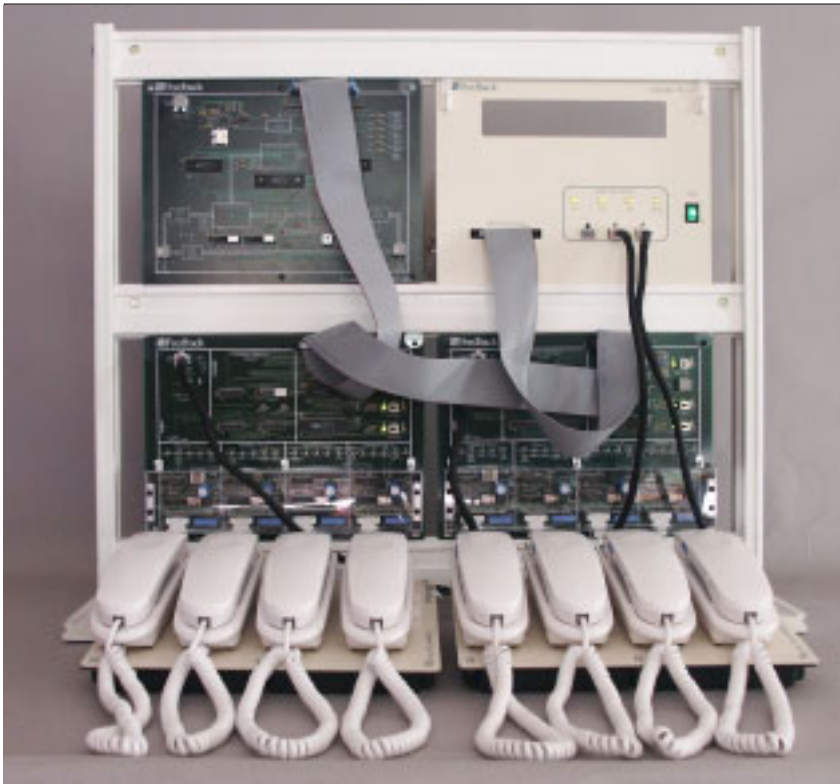

Description

The system comprises:

- Controller
- 2 Digital Switching Centre Boards
- 2 Four Telephone Handset Kits
- Trunk Networks Board

In addition to the curriculum covered by 58-002 and 58-003 the Trunks Network Board has three transit switches and extends the work to cover transit switching and signalling.

The system can be configured as four local switching centres, to cover simple transit switching, two level transit switching, non-associated signalling and the use of ITU-T type transaction capability messages to control system testing.

For ease of use and to accommodate all the modules on the student bench a vertical mounting-rack is available as an optional extra.

All systems require the use of a standard PC.

The additional curriculum includes assignments on the following topics:

Transit Switching Centre

- Numbering
- Transit Switch CSTD
- Transit Signalling

Transit Switching Call Progress

- Transit Switch Centre
- Originating Switch
- Destination Switch

Two Level Transit Switching

- Numbering
- Dialling CSTD
- Routeing Tables

Two Level Transit Call Progress

- Signalling
- 1st & 2nd Level Switches

Non-associated Signalling

- Signalling
- Call Progress

System Testing

- TCAP Signalling
- Testing
- Manual Testing

Tender Specifications

Telephony Training System 58-001

A self-contained, open-board based, Telephony trainer using software control and computer-assisted instruction. The system should contain a 100Msample/s Rapid Access Terminal with USB interface (to connect to a PC with a Windows operating system); Telephone and Interface workboard; TDM/PCM Principles workboard and accompanying software. The system should operate with computer aided laboratory software which provides on-screen instruction, control and instrumentation for twelve computer-based assignments are provided with the system.

Digital Switching System 58-002

A self-contained, open-board based, Digital Switching Telephony trainer using software control and computer-assisted instruction. The system should contain a Controller with power outputs and microprocessor-based circuitry for control; USB interface (to connect to a PC with a Windows operating system); a Digital Switching Centre workboard; four telephones with telephone tray and accompanying software. The system should operate with computer aided laboratory software which provides on-screen instruction, control and instrumentation for twelve computer-based assignments are to be provided with the system.

Digital Telephony Training System 58-003

A self-contained, open-board based, Digital Telephony trainer using software control and computer-assisted instruction. The system should contain a Controller with power outputs and microprocessor-based circuitry for control; USB interface (to connect to a PC with a Windows operating system); a Digital Switching Centre workboard; four telephones with telephone tray and accompanying software. The system should operate with computer aided laboratory software which provides on-screen instruction, control and instrumentation for twenty-four computer-based assignments.

Digital Trunk Network System 58-004

A self-contained, open-board based, Digital Trunk Networks trainer using software control and computer-assisted instruction. The system should contain a Controller with power outputs and microprocessor-based circuitry for control; USB interface (to connect to a PC with a Windows operating system); two Digital Switching Centre workboards; eight telephones on telephone trays and accompanying software. The system should operate with computer aided laboratory software which provides on-screen instruction, control and instrumentation for thirty computer-based assignments.

Telephony Trainer Product Numbers

Listed below are the product numbers of the constituent parts of the two Telephony Trainer Workstations. Each of the workstations may be ordered as a complete system, using the composite order numbers given at the start of the relevant section.

However, should you wish to cover only part of the described curriculum you may not need all of the modules in the workstation. In such cases you may order just the modules that you do require. Please contact either your local agent, or Feedback, if you require more information.

Telephony Training System

58-001 composite equipment:

Rapid Access Terminal (RAT)	92-200
Telephone and Interface	58-100
TDM/PCM Principles	58-110
Telephony Trainer Discovery Software	58-912

Digital Telephony Training System

58-003 composite equipment:

Controller	58-121
Digital Switching Centre x2	58-122
Telephone Tray x2	58-123
Digital Switching System Discovery Software	58-914

Digital Switching System 58-002 composite equipment:

Controller	58-121
Digital Switching Centre	58-122
Telephone Tray	58-123
Digital Switching System Discovery Software	58-914

Digital Trunk Network System 58-004 composite equipment:

Controller	58-121
Digital Switching Centre x2	58-122
Telephone Tray x2	58-123
Trunk Network Board	58-140
Digital Switching System Discovery Software	58-914

Ordering Information

To order any of the Telephony Systems simply quote the title and number of the workstation as given at the start of each section.



Feedback Instruments Limited

Park Rd, Crowborough, East Sussex,
TN6 2QR, England.

Tel: +44 (0) 1892 653322

Fax: +44 (0) 1892 663719

E-mail: feedback@fdbk.co.uk

Website: www.fbk.com

For further information on Feedback equipment please contact: