

# Modeling of Gigabit Backplanes from Measurements

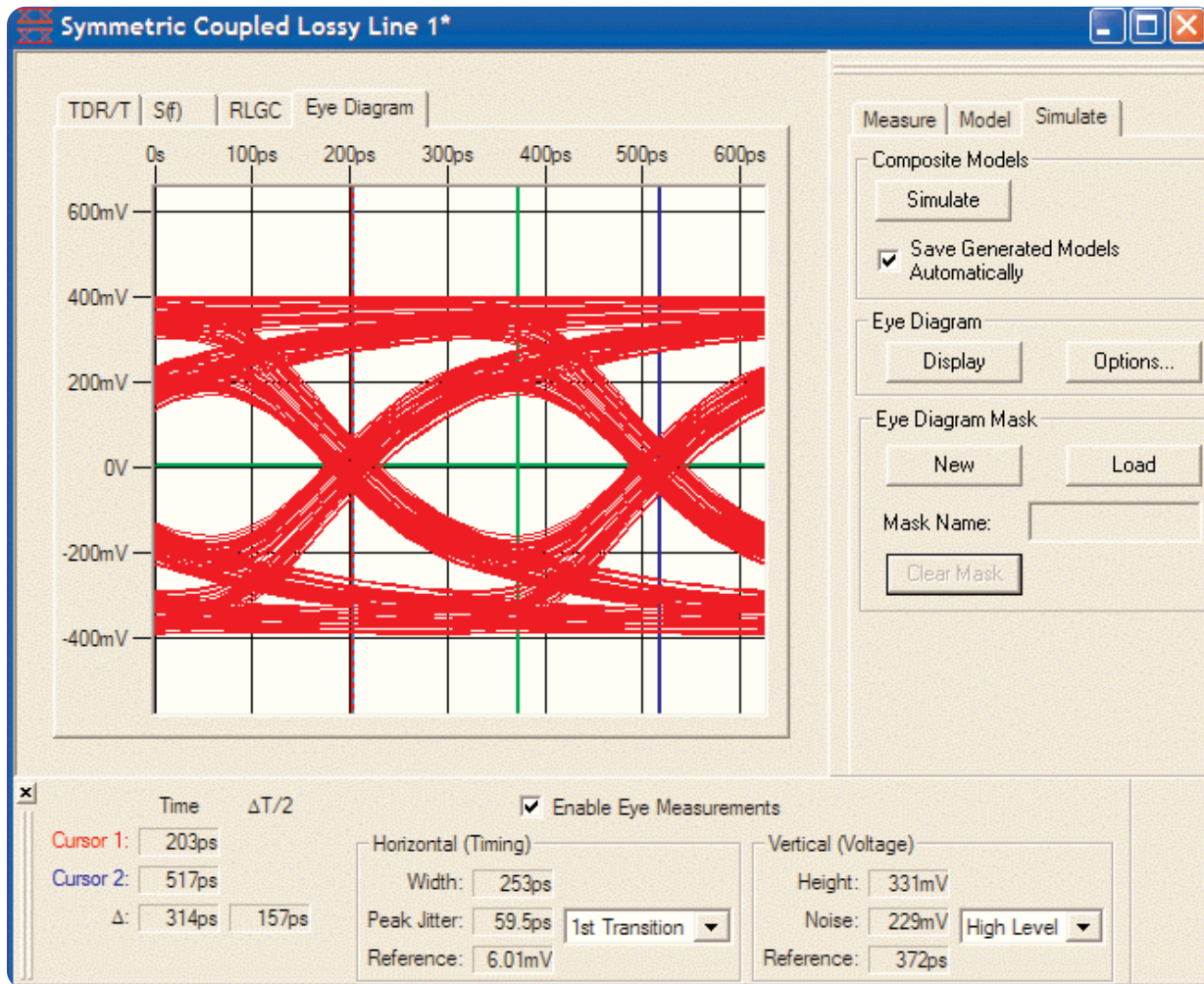

## Introduction

In past few years, the communication and computer industries indicate rapidly increasing demand for accurate SPICE and IBIS models that are able to perform at gigabit speed range. At these speeds, interconnects appear to be complex and often distributed structures and require careful design techniques. Signal integrity becomes a key factor in achieving reliable performance of the digital system design. The signal integrity issues such as frequency dependent transmission and reflection

losses, crosstalk coupling, and signal dispersion become greatly pronounced especially when the interconnect structure is electrically long. The modeling challenges of the backplane structure are evident from the designer's point of view and need to be addressed in order to achieve a reliable digital system design and simulation. This paper presents a detailed procedure for generation of the gigabit backplane model from measurements with IConnect signal integrity software.

## Challenges of Backplane Modeling

It is well known that even at low frequencies, the interconnect structure is not a simple conductor. It has certain characteristics and could exhibit resistive, inductive, or capacitive behavior. When the signal enters a gigabit range, interconnect becomes a distributed structure with specific time delay. As the complexity of the circuit board grows it becomes more difficult to achieve reliable common ground, which provides current return path. The differential signaling scheme is commonly used to overcome this difficulty by providing a virtual signal ground and other advantages.

Other important reasons for the wide acceptance of the differential coupled lines in the gigabit backplane design are offering benefits of increased immunity to the common noise and reduced electromagnetic interference (EMI) between devices [1]. A coupled structure can be fully described by two modes of propagation: even and odd. When signaling is performed with one of these modes for two-signal-line differential pair the signal propagates undistorted [2]. Since the system's noise has common component, the odd mode signal is used to transmit the data. Each line in the odd mode of propagation carries a single bit of data of the same amplitude but opposite polarity. When the signals are subtracted at the receiver's side, the common noise components ideally are canceled out.

The physical world however is not ideal. Since a typical backplane structure contains such elements as connectors, vias, board traces, bends and other discontinuities, the signal integrity issue arises even when the differential signaling scheme is used (Figure 1). A digital designer has to be able to accurately predict and model the

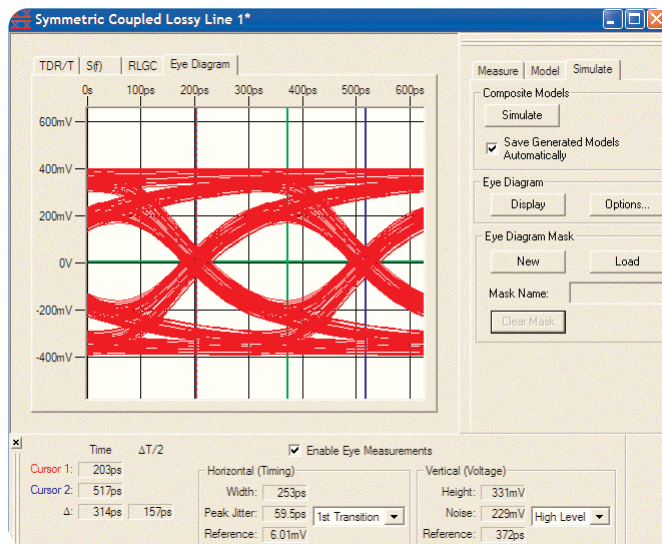

► **Figure 1.** Eye diagram generated at 3.2 Gbit/s and 80ps 20-80% rise time for the FCI AirMax VS? backplane assembly. Eye opening is 331 mV and 253 ps, and peak-to-peak jitter is 59.5 ps.

effects of these signal integrity issues. When a backplane prototype is manufactured it is critical to analyze its performance as a part of the whole system. That is where the measurement-based models provide most of the benefits. The circuit element values that model discontinuities and physical features of a typical backplane can be determined from the time domain measured data making interconnect modeling software to be indispensable tool for every digital designer. A TDR oscilloscope or a Vector Network Analyzer (VNA) combined with TDA Systems's IConnect software allows effectively generate accurate SPICE and IBIS models based on the real life measurements helping to achieve success in the rapidly changing high-tech industry.

### Backplane Topological Models

There are many different modeling approaches that can be used to model the backplane structures. They are divided in two major categories: behavioral and topological (Table 1). Behavioral or data driven model replicates the behavior of the measured device based on the mathematical behavior of the measured waveform. The IConnect's MeasureXtractor modeling technology allows automatic model extraction of two-port or four-port models, which corresponds to single-line and coupled-line circuit [3]. The topological models represent real geometrical features of the measured structures. The greatest benefit of using the topological models in backplane structures is the ability of a designer to look at each individual component and tweak them to achieve desired performance.

Depending on the application requirements the topological models for backplane structures could be single ended or coupled. For example, if the primary interest is an odd mode of propagation the model just for differential impedance could be built to analyze the backplane's behavior. The modeling process for backplane in odd mode only is described in [4]. However, if it were desired to analyze common mode noise rejection then the fully coupled model would be the best choice. Since any signal traveling a differential line could be decomposed in even and odd components, the fully coupled model provides a complete description of the system assuming negligible crosstalk from the adjacent lines. The resulting model will have effectively 4-ports: two ports for input signal and two for the output.

	Behavioral	Topological
Measurement requirements	Requires full-port measurement	Just TDR (reflection) is sufficient
Topology selection	Automatic, no user intervention	User-controlled (easy and intuitive from TDR measurements)
Model extraction	Automatic, no user intervention	User-driven; more labor intensive and require more skill
Type of models	"Black-box," no internal changes allowed	Intuitive, topology correlates to model
Limitation	Large model size for long interconnects (backplanes, cable assemblies)	Efficient model extraction processes exist for large interconnects
Application	Quick inclusion of S-parameter or TDR/T measurements into simulation; the "do-it-all" modeling tool	Comprehensive modeling, "what-if" scenarios analysis, signal integrity troubleshooting and fault-finding

► **Table 1.** Comparison of behavioral and topological modeling approaches.

## Modeling of Gigabit Backplanes from Measurements

### ► Application Note

A backplane test system typically includes the test daughtercards with connectors followed by the uncoupled traces, coupled daughtercard-to-backplane connector header receptacle, coupled backplane traces and vias (Figure 2). As a differential signal propagates through the device under test (DUT) it sees the discontinuities due to all transitions. Therefore it would be reasonable to consider the effects of each component when a topological model is constructed. IConnect software allows obtaining the circuit models for each individual part, and then combining them in one assembly.

### Data Acquisition

Given that the modeling is performed on the measured data it is critical to obtain reliable measurement of the backplane. The TDR oscilloscope that provides high bandwidth of approximately 20 GHz is preferable to use. It is also important to follow good measurement practices while working with high precision instrument, such as:

- Let the instrument warm up for at least 20-30 minutes before performing the measurements
- Perform the required calibrations
- Use good quality low loss cables and probes
- Use a lot of averaging to reduce noise

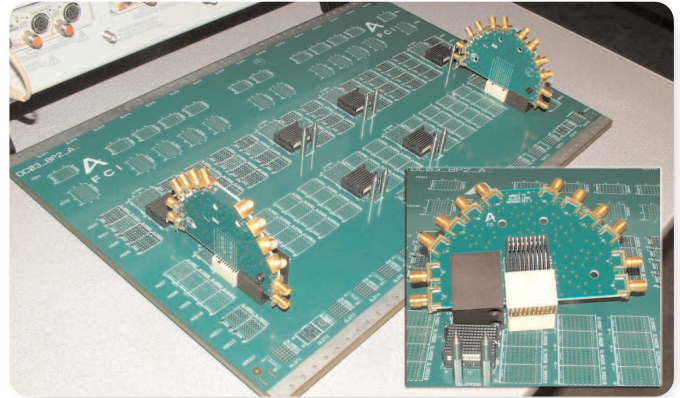

► **Figure 2.** FCI AirMax VS? backplane with daughtercards attached. The daughtercard on the left shows the main features of the typical test daughtercard such as SMA connectors and a coupled right angle header.

- Use a maximum number of acquisition points
- De-skew the channels in the TDR-oscilloscope, as specified by your oscilloscope manual.

The fully coupled model is a four-port structure, and in order to fully characterize it the instrument with four channels is desired: two channels are for reflection and two for transmission measurements. In some cases it is not possible to obtain the measurements of all four ports and IConnect can be very handy here allowing to build a model based only on TDR reflection measurement. Table 2 lists the waveforms that are recommended to have to build a typical backplane model.

Structure	IConnect Model	Waveforms	Termination	Comments
Backplane-daughterboards assembly	Coupled Lossy Line	Odd reference	Open	Acquired at the end of connecting cable
		Odd Reflection Even Reflection	Matched* or Open	* When it is difficult to measure the transmission, the coupled lossy line model could be built using just reflection waveforms.
		Odd Transmission* Even Transmission*		
DaughterCard**	Single Line Model for uncoupled connectors and traces	Odd Reference	Open	Acquired at the end of connecting cable
	Lossy line for lossy traces	Odd Reflection	Open	Acquired with daughter card detached from the backplane
	Symmetric Coupled Lines for coupled receptacle connector and coupled lossy line for coupled daughtercard traces	Odd Reference	Open	Acquired at the end of connecting cable
Odd Reflection Even Reflection		Backplane Connected	The instrument's window is adjusted to capture the behavior of the receptacle connector	

► **Table 2.** Waveforms recommended to build a typical backplane model with connected daughterboards. \*\* For identical daughterboards only one needs to be measured.

When modeling the daughterboard and the backplane losses, the time domain acquisition window must be long enough to capture all the transitions corresponding to the DUT. However, when modeling a high-speed connector, it is preferable to keep the window relatively short, in order to achieve sufficient resolution and resolve the connector details.

### Modeling Process

Creating a model using the data that was acquired with exceedingly fast rise times will result in unnecessary complexity. Hence, before starting the modeling process it is good to determine the range of validity in terms of measurement rise time or equivalent bandwidth. Then the waveforms could be filtered with IConnect to meet the required specifications. For the example considered

in this paper the measured waveforms were filtered to 80ps 20-80% rise time. In view of the fact that the backplane assembly consists of the backplane itself and the daughterboards, the modeling process could be split in two general stages: the backplane and the daughterboard modeling. The high-speed connector interconnecting the daughterboard and the backplane are modeled as a part of the process.

### Backplane Modeling

The step response of long backplane's traces is dominated by the frequency dependent transmission line losses. Skin effect and dielectric loss are two major contributors to the rise time and amplitude degradation of the signal [5] making the symmetric coupled lossy line to be a perfect candidate for the backplane traces modeling.

# Modeling of Gigabit Backplanes from Measurements

## ► Application Note

After the required waveforms are loaded to the IConnect modeling window the lossy line model could be optimized to a very high degree of accuracy. Moreover, IConnect allows for the manual user input, and the models parameters could be adjusted to get an excellent correlation in time and frequency domains (Figure 3). To provide a good starting point, the DC circuit values can simply be measured with a digital voltmeter and then fixed with “fix” feature of IConnect for further optimization process. When the symmetrical coupled lossy line model is verified with linked simulator of choice it can be saved for the final assembly. To properly scale the interconnect length, the user can use the scaling function in IConnect lossy line model.

### Daughtercard Modeling

To decide what models are best suitable to simulate the daughtercard’s behavior it is practical to analyze the true impedance profile generated with IConnect. For this purpose coupled line modeling feature of IConnect was used. (Figure 4). There are three main regions exist in the impedance profile for the daughter card. As the signal propagates it sees the SMA’s connector area, then it enters to the daughtercard trace region. These two regions represent uncoupled lines and could be modeled with single line feature. When signal comes to the receptacle area it becomes coupled with the adjacent trace, here the symmetric coupled model is most suitable.

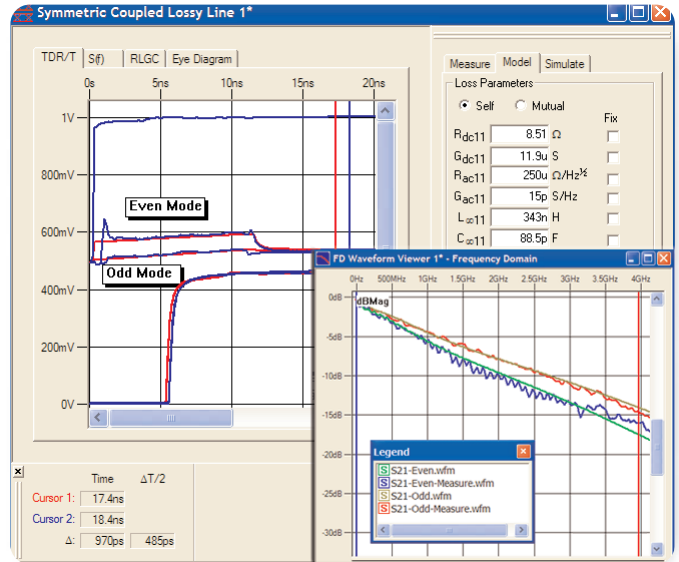

► **Figure 3.** Coupled lossy line, correlation between modeled and measured values. The only significant difference in time domain data is observed for the daughtercard area, which ought to be modeled in separately.

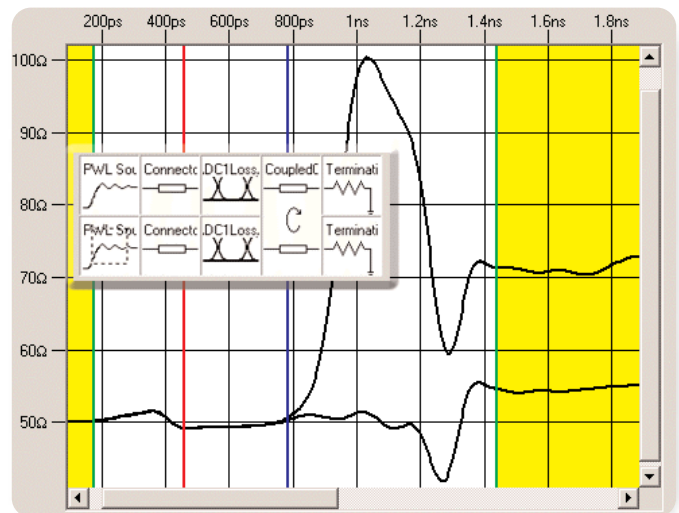

► **Figure 4.** True impedance profile of the daughter-card structure and model topology. Uncoupled regions are modeled with partitioned transmission lines and lossy line, whereas a coupled receptacle modeled with symmetric coupled lines.

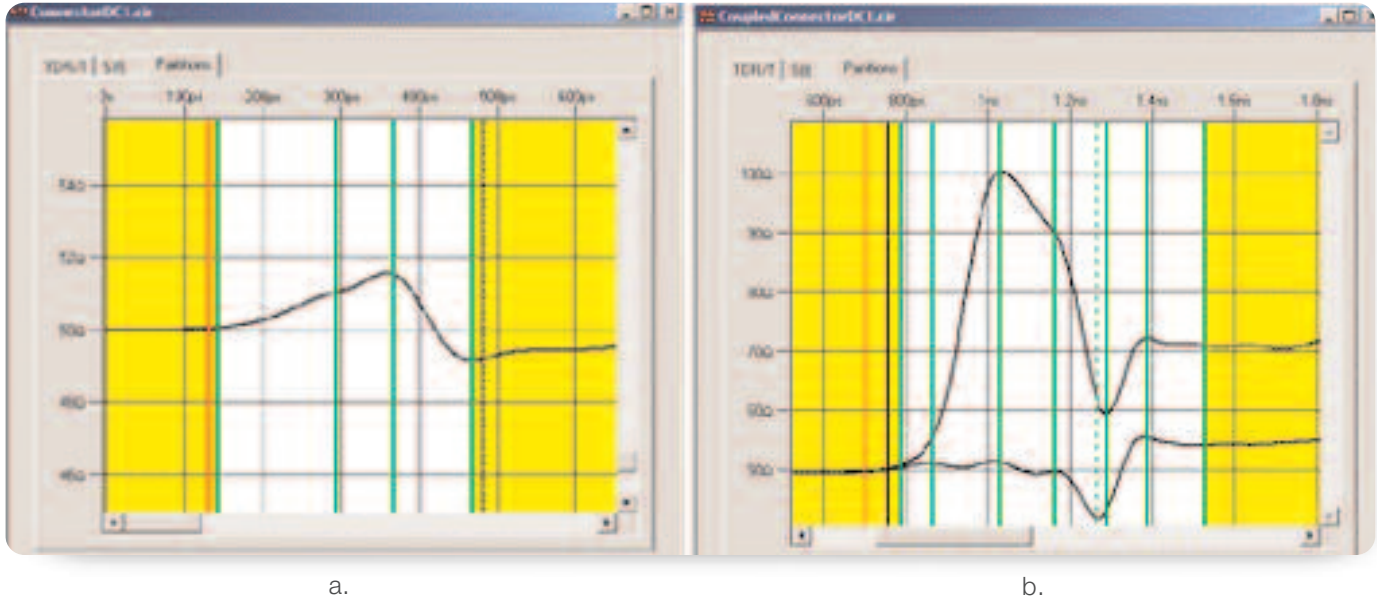

► **Figure 5.** Partitions performed for uncoupled (a) and coupled (b) regions of the daughtercard. Green lines represent partitions, which were placed at the beginning of each impedance change.

The SMA connector and the receptacle areas can be easily partitioned to obtain a better fit. The partitions are placed at each impedance change and represent different circuit element in SPICE or IBIS model (Figure 5).

After all pieces of the daughtercard's circuit model are put together, the HSPICE simulation reveals excellent correlation shown in Figure 6. If the second daughter card is same as the one that was just generated, the circuit model could be reused by interchanging the port numbers in the netlist.

# Modeling of Gigabit Backplanes from Measurements

## ► Application Note

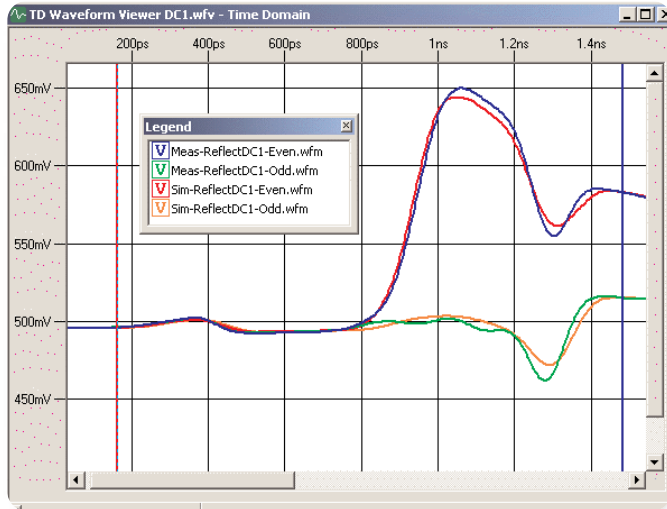

► **Figure 6.** Correlation between simulated and measured waveforms for the daughtercard assembly.

### Backplane Assembly

After the models obtained for the daughter card and backplane are verified with the circuit simulator of choice the models can be assembled in one composite. During the assembly process the length of the symmetric coupled lossy line model needs to be scaled down to account for the length of elements inserted in the circuit model. Figure 7 shows the resulting circuit model topology for a complete backplane assembly. Each box represents the sub-circuit of the composite model.

The model simulation reveals excellent correlation between the measured and modeled values for both even and odd modes of excitation (Figure 8).

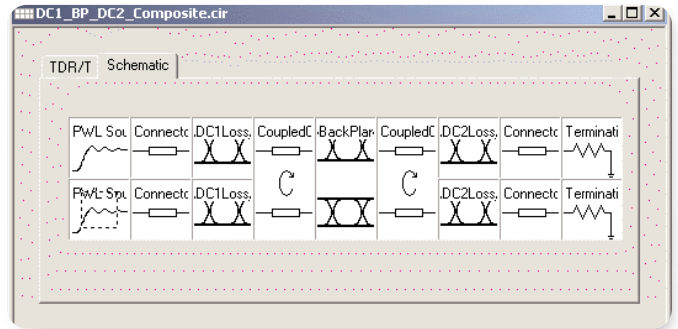

► **Figure 7.** Complete model topology for the backplane assembly. Each box represents a sub-circuit of the composite model.

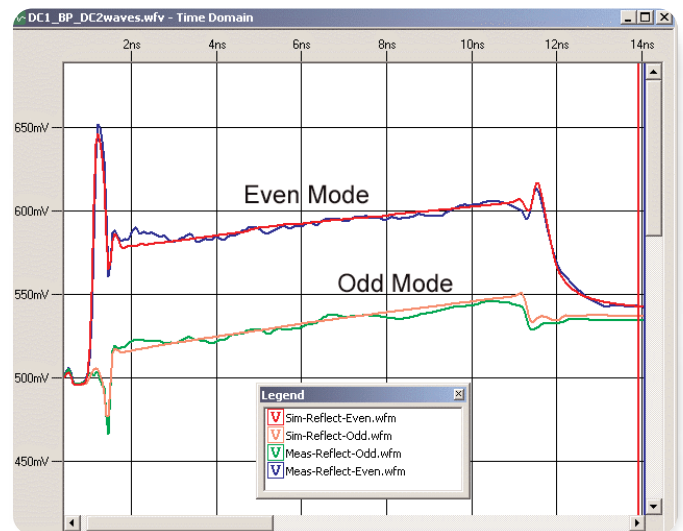

► **Figure 8.** Correlation between the circuit model simulated with HSPICE and measured data for the backplane assembly.

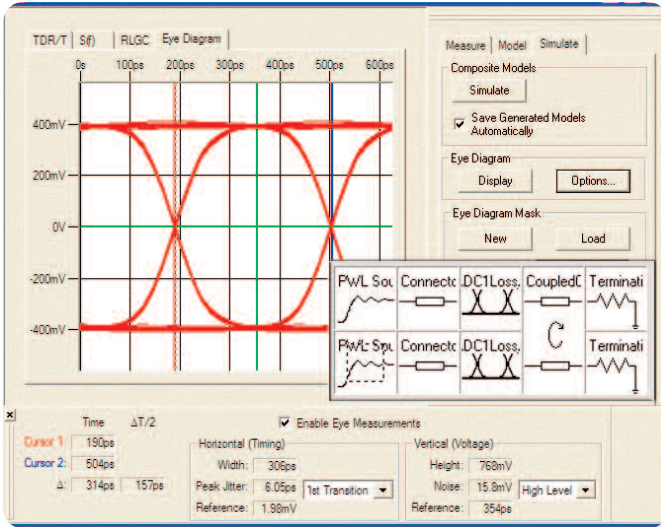

▶ **Figure 9.** Eye diagram generated at 3.2 Gbit/s and 80ps 20-80% rise time for the daughtercard model only. Eye opening is 768mV and 306ps, and peak-to-peak jitter is 6.05ps.

### Model Analysis with an Eye Diagram

It is often desired to analyze the effects of different parts of the backplane on the eye diagram. The topological model is perfectly suitable for such analysis because it allows acquiring transmission waveforms at the different stages of the circuit topology. Once a good approximation of the actual measurement is obtained, we can remove or add different design components. For example to approximate the eye diagrams for the daughtercard and the backplane, we simulate one transmission waveform for the daughtercard and the connector, and

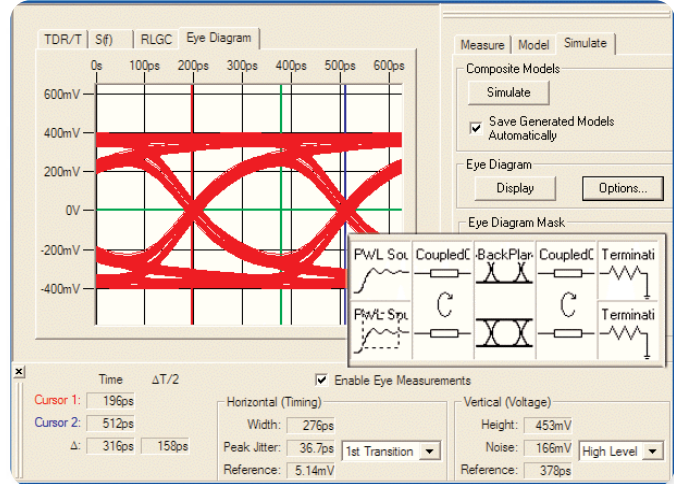

▶ **Figure 10.** Eye diagram generated at 3.2 Gbit/s and 80ps 20-80% rise time for the backplane model only. Eye opening is 453mV and 276ps, and peak-to-peak jitter is 36.7ps.

the other with only the backplane and two connectors at the ends. Then the saved waveforms could be used to generate eye diagrams.

Eye diagram generated with this approach shown in Figure 9 and Figure 10 indicate that the main contributor to the eye diagram closure is a backplane structure with the connectors. The daughtercard alone produces an eye opening of 768mV and 306ps, and peak-to-peak jitter is 6.05ps for the eye diagram generated at 3.2Gbit/s and 80ps 20-80% rise time, while the backplane model generates an eye opening of 453 mV and 276 ps, and peak-to-peak jitter is 36.7 ps at the same conditions.

## Modeling of Gigabit Backplanes from Measurements

► Application Note

### Summary

A complete modeling methodology for gigabit backplane modeling is presented. With the TDR-based measurements and analysis techniques a designer can produce accurate and reliable models for the gigabit system interconnect.

### Acknowledgments

The author would like to thank Dana Bergey of FCI for providing FCI AirMax VS backplane to acquire the measurement data and for reviewing this paper.

## Bibliography

[1] D. A. Smolyansky, S. D. Corey, "Characterization of Differential Interconnects from Time Domain Reflectometry Measurements," – Microwave Journal, Vol. 43, No. 3, pp. 68-80, TDA Systems application note DIFF-1099

[2] E. Bogatin, "Signal Integrity Simplified," – Prentice Hall, 2004

[3] D. A. Smolyansky "Lossy Line Simulation and Analysis," – Printed Circuit Design Magazine, March 2003.

[4] D. A. Smolyansky, "Signal Integrity Modeling of Gigabit Backplanes, Cables and Connectors Using TDR," – EDN Magazine, July 2004, pp. 63-74

[5] H.W. Johnson, m, Graham, "High-Speed Digital Design, A Handbook of Black Magic" – Prentice Hall, 1993

**Contact Tektronix:**

- ASEAN / Australasia / Pakistan** (65) 6356 3900
- Austria** +41 52 675 3777
- Balkan, Israel, South Africa and other ISE Countries** +41 52 675 3777
- Belgium** 07 81 60166
- Brazil & South America** 55 (11) 3741-8360
- Canada** 1 (800) 661-5625
- Central East Europe, Ukraine and Baltics** +41 52 675 3777
- Central Europe & Greece** +41 52 675 3777
- Denmark** +45 80 88 1401
- Finland** +41 52 675 3777
- France & North Africa** +33 (0) 1 69 86 81 81
- Germany** +49 (221) 94 77 400
- Hong Kong** (852) 2585-6688
- India** (91) 80-22275577
- Italy** +39 (02) 25086 1
- Japan** 81 (3) 6714-3010
- Luxembourg** +44 (0) 1344 392400
- Mexico, Central America & Caribbean** 52 (55) 56666-333
- Middle East, Asia and North Africa** +41 52 675 3777
- The Netherlands** 090 02 021797
- Norway** 800 16098
- People's Republic of China** 86 (10) 6235 1230
- Poland** +41 52 675 3777
- Portugal** 80 08 12370
- Republic of Korea** 82 (2) 528-5299
- Russia & CIS** 7 095 775 1064
- South Africa** +27 11 254 8360
- Spain** (+34) 901 988 054
- Sweden** 020 08 80371
- Switzerland** +41 52 675 3777
- Taiwan** 886 (2) 2722-9622
- United Kingdom & Eire** +44 (0) 1344 392400
- USA** 1 (800) 426-2200

For other areas contact Tektronix, Inc. at: 1 (503) 627-7111

Last Updated June 15 2005

**For Further Information**

Tektronix maintains a comprehensive, constantly expanding collection of application notes, technical briefs and other resources to help engineers working on the cutting edge of technology. Please visit [www.tektronix.com](http://www.tektronix.com)



Copyright © 2005, Tektronix, Inc. All rights reserved. Tektronix products are covered by U.S. and foreign patents, issued and pending. Information in this publication supersedes that in all previously published material. Specification and price change privileges reserved. TEKTRONIX and TEK are registered trademarks of Tektronix, Inc. All other trade names referenced are the service marks, trademarks or registered trademarks of their respective companies.

7/05 FLG/WOW

85W-18992-0

